

[CONTRIBUTION FROM THE CHEMICAL ENGINEERING DEPARTMENT OF THE
MASSACHUSETTS INSTITUTE OF TECHNOLOGY]

THE APPLICATION OF THE PHASE RULE TO THE CALCULATION OF LIQUID AND VAPOR COMPOSITIONS IN BINARY SYSTEMS. DEVIATIONS FROM RAOULT'S LAW FOR HYDROCARBON MIXTURES¹

BY GEORGE CALINGAERT AND LAUREN B. HITCHCOCK²

RECEIVED DECEMBER 27, 1926

PUBLISHED MARCH 9, 1927

Introduction

The determination of the composition of a liquid and of the vapor in equilibrium with it has been the object of many investigations. The importance of such work need hardly be emphasized. From accurate knowledge of such data, conclusions can be drawn as to the thermodynamic behavior of the various constituents, and valuable help can be obtained for the correct design of fractionating apparatus involving liquid-gas equilibria, such as distilling columns and absorption towers. The variety of the methods used, as shown by a study of the literature, suggests at once the experimental difficulties involved, chief among these being the determination of the vapor composition. As will appear later in this paper, a common source of error is the assumption that the composition of the liquid phase at equilibrium is identical with that of the mixture introduced in the system at the start. It is the object of this paper to present a method by which the composition of the vapor and liquid phases in a binary system at equilibrium may be calculated accurately from experimental data involving only the measurements of total pressures and vapor volumes.

Principle.—The vapor pressure of a pure hydrocarbon is constant at constant temperature and is, for instance, independent of the relative amounts of vapor and liquid present. If the volume offered to a certain amount of a pure substance is increased while the temperature is kept constant, the pressure observed will be constant as long as the two phases are present. In other words, an isothermal plot of V against P will give a straight line, parallel to the V axis, where V represents vapor volume. If a binary system be considered, composed of substances miscible in the liquid state, the composition of the vapor is in general different from that of the liquid. A given system of this sort being expanded isothermally, a large proportion of the more volatile constituent vaporizes. This will change the composition of the remaining liquid and result in a decrease in pressure. In this case a plot of V against P gives a curve, the lower pressures corresponding to the higher volumes. For any pair of com-

¹ Published by permission of the Chief of Field Artillery.

² Lieutenant of Field Artillery, U. S. Army.

ponents, a family of such curves can be obtained by varying the proportions of the individual constituents in the original mixtures. The distance of the curves from the V axis will increase as the mixtures become richer in the lighter constituent, indicating a higher vapor pressure at the same vapor volume (Fig. 4).

According to the phase rule, such two-component, two-phase systems have two degrees of freedom. It follows that if values are assigned for two independent variables of any system, the system is thereby fully defined. Choosing pressure and temperature as independent variables, it can be said that all the systems which show the same pressure at the same temperature are identical and that, for instance, they have the same liquid and the same vapor composition. Such pairs or series of identical systems can be found on a family of isothermal V - P plots, wherever two or more curves cross a line of constant pressure.

Experimental Part

Apparatus.—The apparatus, made entirely of Pyrex (Fig. 1), is composed of a 100cc. nitrometer tube A, surmounted by an accurately calibrated bulb of about 1cc. capacity. A three-way stopcock connects A, first to a 50cc. gas buret B and a reservoir D from which the lighter hydrocarbon is to be vaporized into B, and second to a reservoir C containing the hydrocarbon which is to be introduced as a liquid. All the connections are made through oblique stopcocks, with suitable connections, to allow the evacuation of any part of the apparatus. A and B are immersed in the same constant-temperature water-bath, and are connected through pressure tubing to their leveling tubes. These are made of the same diameter as their respective tubes in order to avoid meniscus corrections. A glycerine-soap lubricant is used on all stopcocks.

The water-bath temperature is read on a thermometer graduated in tenths of degrees and calibrated by the Bureau of Standards, the temperature control of the system being within 0.01° ; the differences between the mercury levels are read from a verified steel scale, corrected, and subtracted from the corrected reading of a mercurial barometer which has been checked with the United States

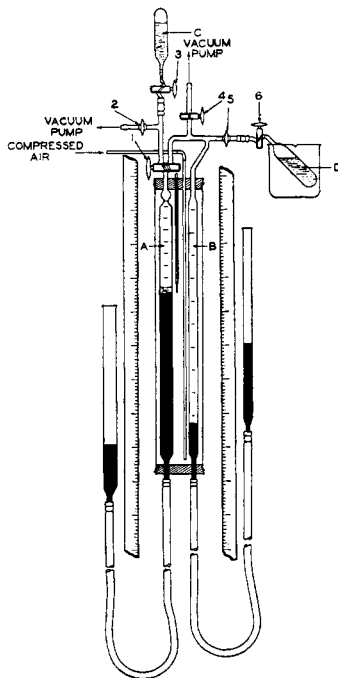

Fig. 1.—Vapor-pressure apparatus.

Weather Bureau. Volumes are read with an accuracy of 0.01 cc., while pressures are within 0.3 mm.

Procedure.—After the apparatus has been evacuated down to less than 1 mm., the mercury meniscus in A is brought into the barrel of the Stopcock 1, and liquid from C is allowed to fill all of the evacuated space between 1, 2 and 3. The leveling tube of A is lowered until the mercury meniscus reaches the top calibration of A, and Stopcock 1 is closed. This brings into A an accurately known volume of liquid, about 1 cc. at 25°, so that from the density the number of millimoles of substance introduced into the apparatus can be calculated. From the bulb D, the lighter component is allowed to evaporate into the buret B and the evacuated space between 1, 4 and 5. By adjusting the leveling tube, care is taken to keep the pressure at all times well below the saturation pressure, in order to avoid condensation. Stopcock 5 is then closed, and the pressure and volume in B are recorded. A and B are then connected through 1 and a certain amount of vapor run from B into A, maneuvering the leveling tubes to keep a slightly lower pressure in A than in B, without allowing the meniscus in A to descend below the point where it is desired to take the first reading. (This was found to be necessary as otherwise, on raising the mercury, a small amount of liquid would be entrapped, thereby changing the amount and composition of the remainder.) V and P are read again in B, and this gives by difference the amount of gas introduced into A. The volume in A is then successively increased by lowering the leveling tube, and readings of V and P are taken after equilibrium has been attained, which takes from 20 to 30 minutes. Each run of this type will lead to a curve of V against P for one given original mixture, from $V = 10$ cc. to $V = 100$ cc., approximately. After this is completed, A is evacuated and filled anew with the same amount of liquid from C and with a different amount of gas from B.³

Calculations

This section gives the method of calculation of the vapor and liquid compositions from the application of the phase rule to the V - P data. The data for butane-pentane mixtures will be used for illustration.

Nomenclature.—In order to save space, we shall use the following symbols: x , mole fraction of butane in the liquid phase; y , mole fraction of butane in vapor phase; L , millimoles of liquid phase; V , millimoles of vapor phase; C_4 , millimoles of butane in the system; C_5 , millimoles of pentane in the system; W , vapor volume, in cc., as read from curve at selected pressure; P , total pressure exerted by the liquid, in mm. of mercury;

³ Theoretically, it should be possible to duplicate the readings by raising the mercury levels after a run. It was found, however, that this required a much longer time to reach equilibrium, probably due to some liquid being entrapped below the mercury meniscus.

1,2, subscripts designating, respectively, the systems richer and poorer in butane. A material and a butane balance in the system will give

$$C_4 + C_5 = L + V \quad (1)$$

$$Lx + Vy = C_4 \quad (2)$$

C_4 and C_5 are known, being the measured input, respectively, of butane and pentane in the system; V is calculated from W (see below), and L may be obtained by difference.

If two systems are known for which P and T are the same, x and y will also be the same, and two equations will be available

$$L_1x + V_1y = C_4 \quad (3)$$

$$L_2x + V_2y = C_4 \quad (4)$$

from which x and y may be readily calculated.

Sample Calculation.—Taking for this purpose the butane-pentane systems at mole % of total butane 9.68 and 8.04, respectively, shown in Fig. 4 as Curves 3 and 4, and selecting a total pressure of 600 mm., the vapor volumes are read off: $W_1 = 82.7$ cc., $W_2 = 49.0$ cc. From Table II, System 4 is composed of 0.968 millimole of butane and 9.03 millimoles of pentane; System 3 of 0.789 millimole of butane and 9.03 millimoles of pentane. Converting W_1 and W_2 to 0°_{298} and 1 atm. pressure ($\frac{600}{760}$), and taking 22,410 cc. as the molecular volume, we get $V_1 = 2.675$ millimoles; $V_2 = 1.584$ millimoles. From Equation 1, $L_1 = 0.968 + 9.03 - 2.675 = 7.323$; $L_2 = 0.789 + 9.03 - 1.584 = 8.235$. This gives, by Equation 2, to $7.323x + 2.675y = 0.968$; $8.235x + 1.584y = 0.789$, whose simultaneous solution yields the values $x = 0.0554$, $y = 0.2105$. Two assumptions are used in this method, which will be examined critically here. (1) The conversion of W , the vapor volume as read, into millimoles of gas, is accomplished by applying the perfect gas law, taking 22,410 cc. as the molecular volume under standard conditions. Before this procedure was adopted the actual molecular volumes of the pure substances were calculated by various methods which included that of saturated vapor densities, Dühring's rule and the law of corresponding states. The discrepancies between the experimental data available far exceed the deviations from the value indicated. Furthermore, the number of moles of vapor present being always much smaller than the number of moles of liquid, a small error in the value of the molecular vapor volume would have an entirely negligible effect on the final result of the calculations. The value of 22,410 cc. is therefore used throughout. (2) Dalton's law of additivity of vapor volumes or partial pressures is implied in the expression Vy . All of the work on the deviations from Dalton's law points to an increase in deviation with increasing pressure, and with dissimilarity between the molecular species. Below one atmosphere, the deviations are less than 1% even for such dissimilar molecules as methane and nitrogen.

Since the pressures recorded here are always lower than atmospheric

and since we are dealing with fairly similar molecules, the assumption of Dalton's law appears justified.

Butane.—This was prepared by the method indicated by Lebeau⁴ and developed in this department by Calingaert and Schaefer,⁵ in order to preclude the presence of any *isobutane*, or other compounds boiling within 100°. It consists briefly of the reduction of an alkyl halide by a solution of sodium in liquid ammonia: $RX + 2Na + NH_3 = RH + NaX + NaNH_2$.

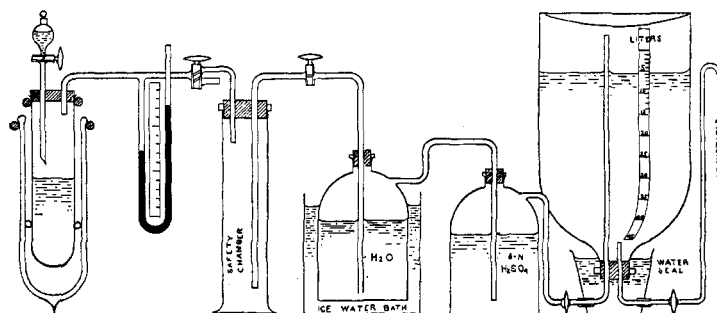

Fig. 2.—Preparation of butane.

Twenty-three and two-tenths g. of *n*-butyl chloride is slowly added to a solution of 11.5 g. of sodium in 300 cc. of liquid ammonia (see Fig. 2). The crude gas, collected over brine after absorption of the ammonia, is purified through a train of sodium in ammonia (to remove RX), bromine water (to remove unsaturated compounds), ice water (to remove octane), and condensed in a carbon dioxide snow-ether mixture (Fig. 3). The butane was purified by successive distillations at 0° until a material was obtained distilling between 773 and 769 mm.

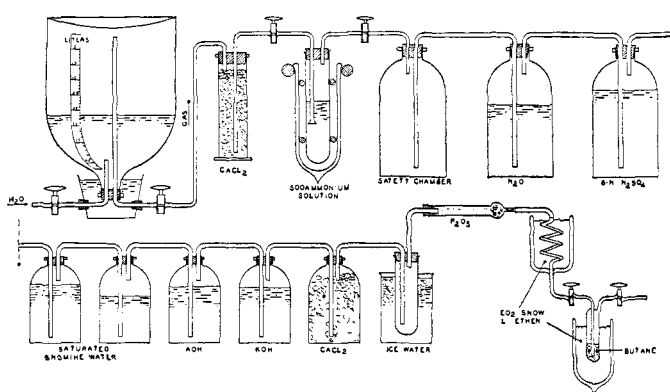

Fig. 3.—Purification of butane.

***n*-Pentane.**—This material, due to the courtesy of Mr. H. D. Wilde of this Department, was obtained by him by fractional distillation of natural gasoline. It boiled at

⁴ Lebeau, *Compt. rend.*, 140, 1042 (1905).

⁵ To be published shortly in "Organic Syntheses," John Wiley and Sons, New York, 1927, vol. 7.

36.00–36.03° at 760 mm., and was redistilled three times at 20° in a closed system, discarding each time the first fraction in order to remove the last trace of air.

n-Heptane.—The crude hydrocarbon was obtained from Professor Edward Kremers of the University of Wisconsin, who secured it by fractionation of Jeffrey Pine Oil.⁶ It was purified by the iodine method developed by Sherk.⁷

Ninety-five cc. from a 1-liter batch which distilled completely at 98.4° at 760 mm. was drawn into a 100cc. bulb and freed from air by suction and heating under gentle shaking.

Benzene.—This was a commercial c. p. grade product, which was merely de-aerated in the same way as the heptane.

Straw Oil.—A sample of this material, which is used as an absorbent oil in the recovery of light liquid hydrocarbons from gases, was kindly furnished by the Humble Oil and Refining Company, Houston, Texas. It showed by cryoscopy a molecular weight of 265; at 25° had a density of 0.838; and exerted no appreciable vapor pressure. Its chemical nature probably approximates that of a light lubricating oil, appreciably different, therefore, from paraffin hydrocarbons.

As a test of their purity, the pressures of the pure hydrocarbons at increasing vapor volume were determined at 25° and are tabulated below.

TABLE I
VAPOR PRESSURE OF PURE HYDROCARBONS AT 25° IN MM. OF HG

Hydrocarbon	V. p., obs.	V. p. from literature
<i>n</i> -Butane	1823	1843 ^a
<i>n</i> -Pentane	521.3	517 ^b
<i>n</i> -Heptane	47.7	46 ^b
Benzene	96.5	96 ^c

^a Only two previous investigators have reported the pressure of *n*-butane in the vicinity of 25°. In 1913, Visser (*Proefschrift*, Leiden, 1913) reported some data which are rather erratic and give but two significant figures. His best curve shows a value of about 1900 mm. at 25°. In 1924, Wilson and Bahlke in their presentation of hydrocarbon data according to thermodynamic principles made the comment that available data for *n*-butane are "notably discordant." In 1926, Dana and associates [*Refriger. Eng.*, June (1926)] gave consistent, accurate data over a large temperature range which yielded the value 1843 mm. at 25°. It must be concluded, therefore, that only the latter investigator obtained reliable data for butane. His value of 1843 mm. compares favorably with that of 1823 mm. obtained in this investigation. His results are open to the criticism that since his butane is fractionated from natural gasoline, it may contain some *isobutane* which would raise the pressure. The value 1823 was preferred, our material having a closer boiling range (8 mm. at 25° as against 10 mm. for Dana's).

^b Young, *J. Chem. Soc.*, 71, 446 (1897).

^c Regnault, Landolt-Börnstein's "Tabellen," Julius Springer, Berlin, 1923, 5th ed., p. 1370.

Results

Pressure-volume relationships were obtained for butane-pentane systems containing from 2.25 to 27.3 mole % of butane; butane-heptane systems containing from 2.00 to 30.50 mole % of butane; butane-benzene systems containing from 1.84 to 14.75 mole % of butane; pentane-

⁶ Kremers, *J. Am. Pharm. Assoc.*, 9, 857 (1920).

⁷ Sherk, *ibid.*, 9, Dec., 1920.

heptane systems containing from 10.05 to 40.6 mole % of pentane; butane-“straw oil” system containing 35.5 mole % of butane. Typical original data, taking butane-pentane systems for example, are given in Table II, all suitable corrections having been applied to the volume and pressure readings.

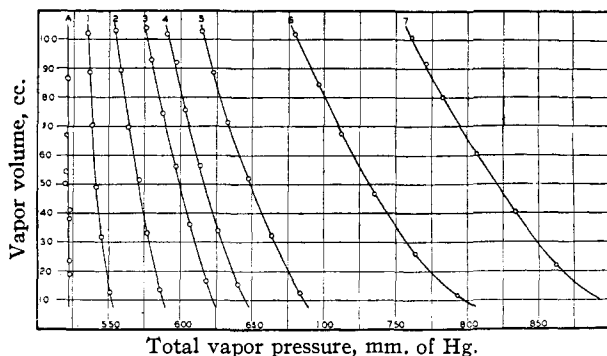

Fig. 4.—Vaporization of butane-pentane mixtures at 25.00°. Mole % of butane in system: A, pure pentane; 1, 2.25; 2, 5.29; 3, 8.04; 4, 9.68; 5, 12.78; 6, 19.90; 7, 27.30.

Treatment of data (see Fig. 4).—The treatment of these data by the method outlined above gave: (1) P - x diagrams showing at 25.00° the

TABLE II
BUTANE-PENTANE MIXTURES
Pressure-Volume Relationships

Curves	1	2	3	4			
	Cc.	Cc.	Cc.	Cc.			
	12.6	13.5	16.7	15.5			
	31.8	33.1	36.2	34.1			
	49.1	51.5	56.2	56.5			
	70.5	69.9	74.6	75.7			
	88.8	89.4	93.0	92.2			
	102.1	103.1	104.0	102.0			
	Mm.	Mm.	Mm.	Mm.			
	551.0	586.0	618.0	640.5			
	545.0	577.0	606.5	626.5			
	541.0	571.5	597.0	614.0			
	538.5	564.0	587.5	603.0			
	536.5	558.5	579.5	597.0			
	535.0	554.5	576.0	590.5			
Curves	5	6	7				
	Cc.	Cc.	Cc.	Mm.			
	12.5	11.5	21.6	862.0			
	32.4	26.1	40.4	833.5			
	52.3	46.8	60.5	806.5			
	71.5	67.5	80.2	782.5			
	88.6	84.5	91.7	771.0			
	102.9	101.8	100.9	761.0			
	Mm.	Mm.	Mm.				
	683.5	793.0	862.0				
	664.0	763.5	833.5				
	647.5	735.5	806.5				
	633.0	712.5	782.5				
	623.0	696.5	771.0				
	615.0	680.0	761.0				
Composition of Mixtures in Millimoles							
Curves	1	2	3	4	5	6	7
C_4	0.2075	0.504	0.789	0.968	1.322	2.242	3.392
C_5	9.03	9.03	9.03	9.03	9.03	9.03	9.03
Total	9.238	9.534	9.819	9.998	10.35	11.27	12.42
Mole % of C_4	2.25	5.29	8.04	9.68	12.78	19.90	27.30

total and partial pressures of each component (Figs. 5, 6, 7, 8, 9); (2) x - y diagrams (Fig. 10), showing actual composition in comparison with the ideal.

TABLE III
SUMMARY OF CALCULATIONS FOR BUTANE-PENTANE

P , mm.	With curves	W_1 , cc.	W_2 , cc.	x	y	Average x	Av. y	Part. press. C_4	Part. press. C_5
550	1,2	119.0	16.0	0.01764	0.113	0.01764	0.113	62	488
555	1,2	101.5	4.0	.02125	.121	.02125	.121	67	488
580	2,3	92.0	26.0	.04165	.174	.04165	.174	101	479
590	3,4	104.5	70.0	.0450	.200				
	2,3	70.0	7.5	.04885	.208	.04772	.200	118	472
	2,4	104.5	7.5	.0493	.193				
600	3,4	82.7	49.0	.0554	.2105	.0554	.2105	126.5	473.5
620	3,4	44.2	14.0	.0726	.237				
	4,5	94.0	44.2	.0675	.266	.0706	.253	157	463
	3,5	94.0	14.0	.0716	.257				
640	4,5	61.5	15.5	.0859	.290	.0859	.290	186	454
680	5,6	101.8	15.6	.1137	.372	.1137	.372	253	427
771	6,7	91.7	21.6	.1730	.500	.1730	.500	385.5	385.5
782.5	6,7	80.2	15.8	.1785	.526	.1785	.526	411.5	371
806.5	6,7	60.5	7.5	.1870	.594	.1870	.594	479.5	327
652.0						Av. 0.0903		214.0	439.0

Table III gives the results of the calculations for butane-pentane systems, in which the last line shows the average values of x and P . These are the coördinates of the point through which the best straight line passes, taking advantage of the fact that in the small composition range covered the pressure curve is very nearly a straight line.

Discussion

The general and specific results of this work will be discussed under separate headings.

1. **Applicability of the Method.**—The consistency of the data obtained is sufficient illustration of the fact that the method can be successfully applied to the determination of P - x and x - y diagrams. While the illustrations presented here cover only a few similar systems, it is obvious that the principle of the method can be applied to any pair of substances, at any concentration and temperature which can be conveniently attained. The present method does away with such dangerous procedures as the assumption of the liquid composition and the computation of the vapor composition by Raoult's law, or the attempt to analyze the vapor phase. With the latter actually determined, direct information is obtained regarding escaping tendency of each constituent. The method could be applied, for instance, to determine the escaping tendency of a reactive substance from various solvents, enabling a comparison to be

made between this tendency and the reactivity in each solvent for any given chemical process.

2. **Vapor Pressure of Hydrocarbon Mixtures.**—For the purpose of comparison, the data given above are summarized in Table IV, which gives for each mixture investigated the per cent. deviations of the total and partial pressures from the pressures calculated from ideality. P designates total pressure; p_h and p_l designate the partial pressures of the heavier and lighter component, respectively. An upward deviation is considered positive. This is not truly a deviation from Raoult's law, since the latter

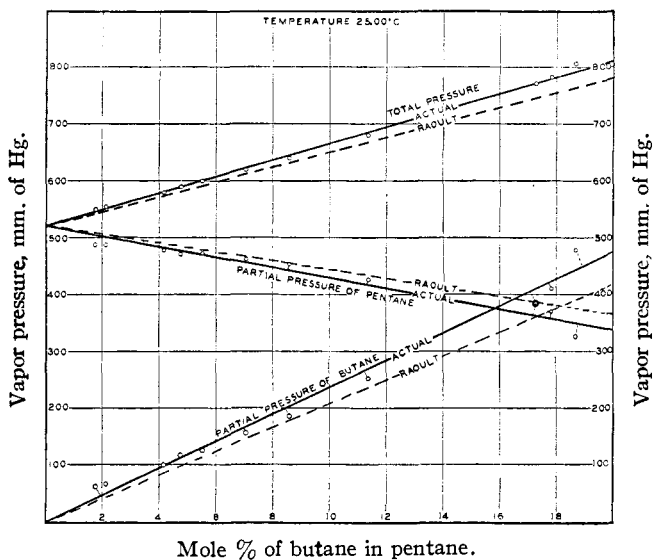

Fig. 5.

is supposed to apply only to the solute over a certain range. However, paraffin hydrocarbon mixtures are often considered to give ideal solutions, that is, exerting partial and total pressures proportional to the mole fractions of the various constituents.

TABLE IV
PER CENT. DEVIATIONS FROM RAOULT'S LAW AT 25° AND 20 MOLE % OF THE LIGHTER CONSTITUENT

Heavy component	Light component	P	p_h	p_l
Heptane	Pentane	7	-16	19
Pentane	Butane	4	-7	14
Benzene	Butane	64	20	75
Straw oil	Butane	-2.6	0	-2.6

An interpretation of the results as brought forth in Table IV is probably best sought in forces which govern attraction and repulsion between

molecules. What seems to be the most reasonable discussion of the subject is given by Hildebrand.⁸ He points out that the same forces which determine the composition of a solution saturated with respect to one of its components operate not only when the solution is saturated, but also when it is more dilute with respect to this component, and will influence all the properties connected with the escaping tendencies of the molecules.

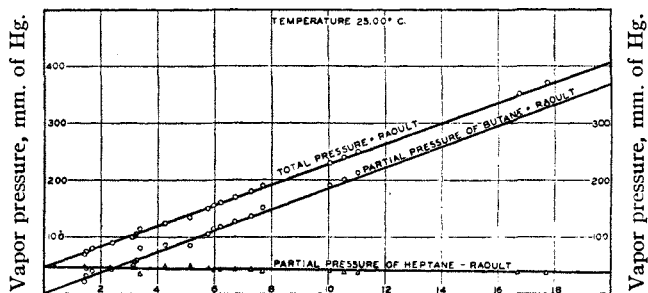

Fig. 6.—Mole % of butane in heptane.

This escaping tendency, he continues, may be manifested as vapor pressure, in which case we have to do with vapor pressure-composition data. The work proceeds to determine as far as possible how the escaping tendencies of the various components of a solution may be expected to vary, first with the composition of the solution, and second with the nature of the

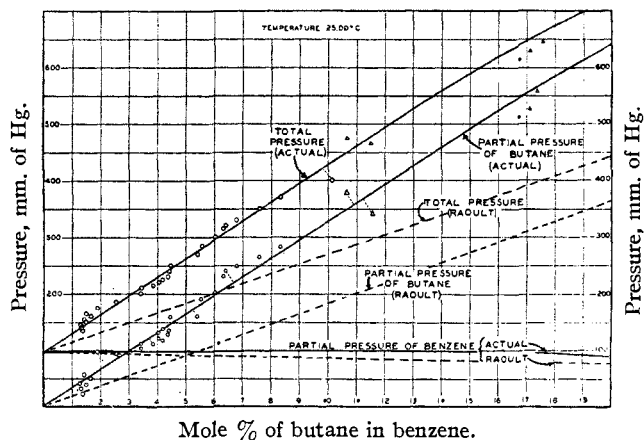

Fig. 7.—○, Hitchcock; △, Schaefer.

components. In recognizing the chemist's simple maxim that "like dissolves like," Hildebrand emphasizes the need of criteria as to what constitutes "likeness," and selects two important attributes of the components which may be expressed quantitatively. These are the polarity and the

⁸ Hildebrand, "Solubility," Chemical Catalog Co., New York, 1924.

internal pressure, or attractive force. Internal pressure is defined as a measure of the internal forces in a liquid, which are enumerated as the attractive pressure between the molecules, the thermal pressure, and the external, or vapor, pressure. Since the latter is of the order of magnitude of one one-thousandth of the first two types of pressure, it is negligible, and either of the former types may be taken as a measure of the existing forces. Consideration of molecular mechanics shows that deviations from Raoult's law arise from differences in degree of polarity and from differences between the intermolecular forces.

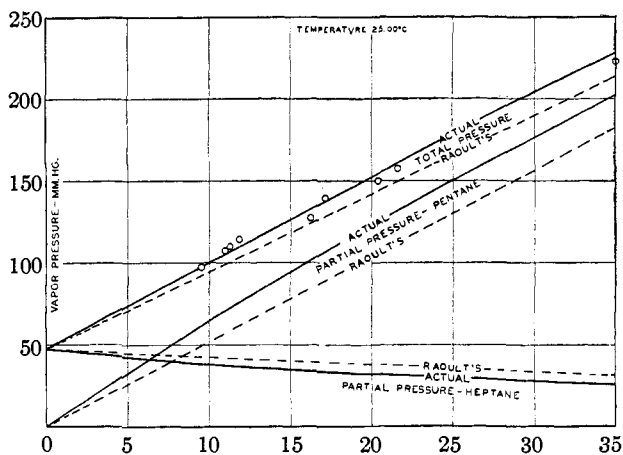

Fig. 8.—Mole % of pentane in heptane.

Following is a list of the values of the electric moment, $\mu \times 10^{19}$, of various hydrocarbon molecules which may be taken as a direct measure of their polarity:⁹ methane, 0.5; *n*-hexane, 0; *n*-octane, 0; benzene, 2. This points to a very low value of the polarity of pentane and butane, and thus a considerable difference between benzene and butane in degree of polarity.

Hildebrand demonstrates various methods of calculating internal pressure, two of which lead to the results given in Table V.

TABLE V
RELATIVE INTERNAL PRESSURES

	From van der Waals' equation	By Hildebrand's formula
Butane	251	51.3
Pentane	280	59.7
Heptane	306	55.5
Benzene	472	85.6

This shows again why benzene and butane may be expected to deviate in an upward direction from ideality, since they differ so greatly in internal pressure as well as in polarity.

⁹ Henri, "La Structure des Molécules," J. Hermann, Paris, 1925, p. 19.

Assuming two non-polar molecular species X_1 and X_2 , Hildebrand states: "If the forces between X_2 and X_2 are greater than the others, . . . the molecules of this species will tend to associate with themselves, squeezing out X_1 and producing positive deviations from Raoult's law . . . the forces between X_1 and X_2 appear to be some simple function of those between the like molecules, permitting the deviation from Raoult's law to be almost proportional to the difference of the cohesions between the like molecules. If the attraction between X_1 and X_2 is abnormally large, negative deviations from Raoult's law appear."

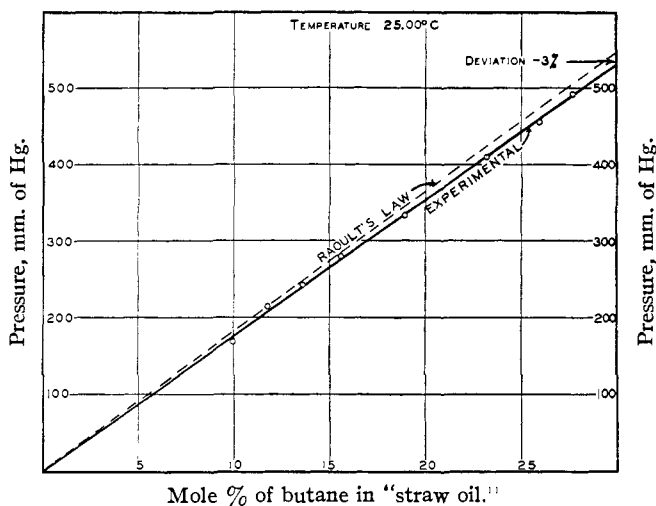

Fig. 9.

In addition, the conclusion is reached that only those substances whose intermolecular forces are equal can obey Raoult's law. Application of these relationships to the specific deviations found shows fairly good agreement of the theory with the facts except in one case. The attractive force between two pentane molecules is indicated as being greater than the attractive force between two butane molecules, which would account for a tendency on the part of the pentane to associate, squeezing out the butane and causing a positive deviation. Analogous reasoning applies to the system pentane-heptane. Table IV shows that the partial pressure of the component having the greater internal pressure is reduced in each system and that the positive deviation in the total pressure is caused entirely by the component that is squeezed out. In the system butane-heptane, where no deviation is found, the relative internal pressures as calculated in Table V seem to be inconsistent. According to the theory, the intermolecular forces in the latter mixture should all be equal, otherwise a deviation must exist. With the limited amount of data now at

hand it is difficult to conclude whether for compounds differing so slightly in polarity and internal pressure, amplification of the theory is necessary, or a better basis is needed for comparing the intermolecular forces.

The system butane-straw oil shows a negative deviation, pointing to an abnormally large attractive force between the butane and the high-molecular-weight hydrocarbons. Since the components are all approximately

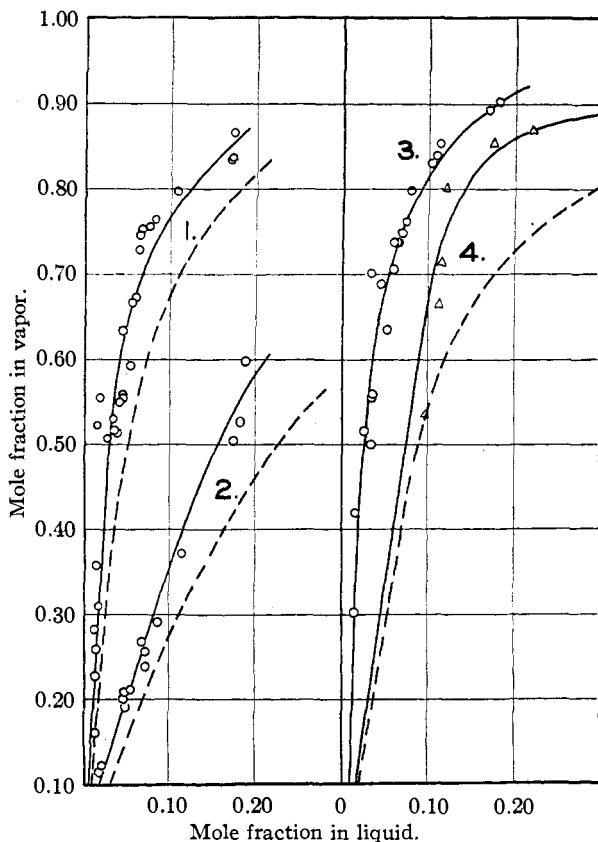

Fig. 10.—X-Y diagram (dotted lines represent ideality).
1, Butane-benzene; 2, butane-pentane; 3, butane-heptane;
4, pentane-heptane.

non-polar in the same degree, the deviation is small. To summarize, the systems butane-pentane and pentane-heptane, having components of nearly equal internal pressures and of the same degree of non-polarity, show small positive deviations from Raoult's law. The system butane-benzene, whose components differ in degree of polarity and in internal pressures to a much greater extent than the former, shows a large positive deviation. The system butane-straw oil, whose components are equally

non-polar, but between which there exists an attractive force greater than the forces between like molecules, shows a small negative deviation. The system butane-heptane, which obeys Raoult's law, is not in accord with the theory of deviations in its present state of development.

3. Data from the Literature.—It was thought advisable to incorporate in this presentation any set of comparable data which could be obtained from the literature. No data were found from which vapor composition could be obtained.

Wilson and Wylde¹⁰ measured deviations from Raoult's law of hexane and benzene, respectively, in several different kinds of oil. Their results agreed qualitatively with those obtained herein, in so far as they are comparable. Hexane in paraffin-base lubricating oil, for example, yields a small negative deviation, while in asphalt-base lubricating oil a considerable positive deviation is found. That behavior seems to agree with the slight negative deviation found here for the system butane-straw oil, and with the large positive deviation for the system butane-benzene.

Leslie and Carr¹¹ give data from which P - x relationships may be derived for hexane-heptane, heptane-octane and hexane-octane mixtures over a fair temperature range. From these data, isothermal P - x diagrams were drawn. These diagrams showed variable deviations from ideality, all negative and amounting to as much as 18.5% at 50 mole % and 25° for hexane-octane mixtures. A close examination of the data further revealed the following anomalies. (1) The deviations from ideality appear to vary greatly with temperature, and to differ greatly from one pair of hydrocarbons to another, as evidenced by Table VI.

TABLE VI
PER CENT. DEVIATIONS OF TOTAL PRESSURE FROM IDEALITY AT 50 MOLE % (LESLIE AND CARR)

	25°	65°	85°	90°
Hexane-octane	-18.5	-15	...	-9.8
Hexane-heptane	0	-3.2	-1.2	...
Heptane-octane	...	-2.3	...	0

(2) The Dühring lines for pure substances are all perfectly smooth and almost straight. It would, therefore, be expected that the lines corresponding to mixtures would have slopes intermediate between those of the two pure constituents, and varying in a regular fashion with varying composition. Instead, these slopes show erratic variations, well beyond the accuracy of the readings and plots, thus pointing to the probable presence of an experimental source of error.

The large negative deviations from ideality suggest molecular association. No evidence of it was ever found for paraffin hydrocarbons. Fur-

¹⁰ Wilson and Wylde, *Ind. Eng. Chem.*, 15, 801 (1923).

¹¹ Leslie and Carr, *ibid.*, 17, 810 (1925).

thermore, the association should probably be accompanied by contraction in volume on mixing, which does not seem to be the case. For these varied reasons, their data seem to be unreliable. The vapor-pressure data of pure substances as reported are consistent within themselves, and agree well with reliable previous investigators. When mixtures are examined, however, the following details of the experimental procedure may account for the grave errors in the final results: (a) the vapor volume seems to be large compared with the amount of boiling liquid; (b) a certain amount of condensate is bound to be present in the condenser; (c) the vacuum pump acting intermittently on the system must pump off some vapors during the 30 minutes taken for each determination; (d) the composition of the boiling liquid is apparently taken as identical with that of the input. In the case of pure substances, where liquid and vapor have the same composition, the results should not be affected by this procedure. Indeed, the vapor-pressure data for pure hydrocarbons are consistent within themselves, and agree very well with those of reliable previous investigators. In the case of mixtures, however, Points a, b and c will tend to make the liquid appreciably richer in the heavier constituent than the mixture introduced in the apparatus at the start. The deviations observed are in the direction which is to be expected if the above explanation holds true. Furthermore, it is greatest for the octane-hexane systems, where the greater difference in volatility would naturally tend to magnify such cause of error. This illustrates the necessity of taking the vapor phase into consideration whenever such data are required. In view of these facts, the data given there do not seem to the authors of the present paper to be at all reliable as far as P - x and x - y diagrams are concerned. The present discussion does not, of course, question the fact fully established by Leslie and Carr, that Dühring's rule applies to mixtures of volatile compounds.

The authors are indebted to Dr. A. Henne, and to Messrs. J. H. Schaefer and H. D. Wilde, for assistance in the work and for some of the materials used. One of the authors is indebted to Major General William J. Snow, LL.D., Chief of Field Artillery, United States Army, for the assignment to this Institution, which made possible the carrying on of the work.

Summary

This paper presents a method by which the equilibrium vapor and liquid compositions in a system composed of two volatile, miscible liquids can be determined accurately from P - V - T data only, and without involving analysis of the phases present. Vapor pressure-composition data are presented from 0 up to 20 and 35 mole % of the lighter constituent for the following pairs of hydrocarbons at 25°: butane-pentane, butane-heptane, pentane-heptane, butane-benzene, butane-straw oil. The per cent. devia-

tions of the total pressures from ideality, at 20 mole % of the lighter constituent, are as follows: butane-pentane, +4; butane-heptane, 0; pentane-heptane, +7; butane-benzene, +64; butane-straw oil, -2.6. These deviations are discussed in the light of polarity and the internal pressure of the molecules. A critical study is offered of related data from the literature.

CAMBRIDGE, MASSACHUSETTS

[CONTRIBUTION FROM THE GATES CHEMICAL LABORATORY, CALIFORNIA INSTITUTE OF TECHNOLOGY]

THE SIZES OF IONS AND THE STRUCTURE OF IONIC CRYSTALS

BY LINUS PAULING¹

RECEIVED JANUARY 25, 1927

PUBLISHED MARCH 9, 1927

The Wave-Mechanics Picture of the Atom

In recent years the old quantum theory, associated principally with the names of Bohr and Sommerfeld, encountered a large number of difficulties, all of which vanished before the new quantum mechanics of Heisenberg.² Because of its abstruse and difficultly interpretable mathematical foundation, Heisenberg's quantum mechanics cannot be easily applied to the relatively complicated problems of the structures and properties of many-electron atoms and of molecules; in particular is this true for chemical problems, which usually do not permit simple dynamical formulation in terms of nuclei and electrons, but instead require to be treated with the aid of atomic and molecular models. Accordingly, it is especially gratifying that Schrödinger's interpretation of his wave mechanics³ provides a simple and satisfactory atomic model, more closely related to the chemist's atom than to that of the old quantum theory.

In Schrödinger's wave mechanics (which has been shown⁴ to be mathematically identical with Heisenberg's quantum mechanics), a conservative Newtonian dynamical system is represented by a wave function or amplitude function ψ , which satisfies the partial differential equation

$$\Delta^2\psi + (8\pi^2/h^2)(W - V)\psi = 0 \quad (1)$$

¹ Fellow of the John Simon Guggenheim Memorial Foundation.

² Heisenberg, *Z. Physik*, **33**, 879 (1925). Born and Jordan, *ibid.*, **34**, 858 (1925). Born, Heisenberg and Jordan, *ibid.*, **35**, 557 (1926); etc. Heisenberg based his theory on the thesis that it should not contain reference to quantities which are in principle unobservable. It is of interest that G. N. Lewis, in 1923, suggested this idea, writing . . . "we should look for no effects which depend upon the momentary position of any electron in its orbit" ("Valence and the Structure of Atoms and Molecules," Chemical Catalog Co., New York, 1923, p. 52).

³ Schrödinger, *Ann. Physik*, **79**, 361, 489; **80**, 437; **81**, 109 (1926); *Phys. Rev.*, **28**, 1049 (1926).

⁴ Schrödinger, *Ann. Physik*, **79**, 734 (1926). Eckart, *Phys. Rev.*, **28**, 711 (1926).